



ALUMINIUM LIGHT CRANE SYSTEM

- > EFFICIENT & ERGONOMIC TO USE
- > LIGHT WEIGHT & VERY SMOOTH OPERATION



FEATURES

- > Lower self-weight in comparison with steel rails enables easy installation & lower operational effort.
- > The surface treatment of the profiles and high quality trolleys facilitates very smooth movement.
- > No chance of falling paint particles as aluminium profiles do not require painting.
- > Complies with the European light crane standard EN16851.
- > An integrated solution of Aluminium Light Crane System and Electric Chain Hoist with Inverter from KITO offers the smoothest material handling experience.



EQ WITH INVERTER

STANDARD LINEUP

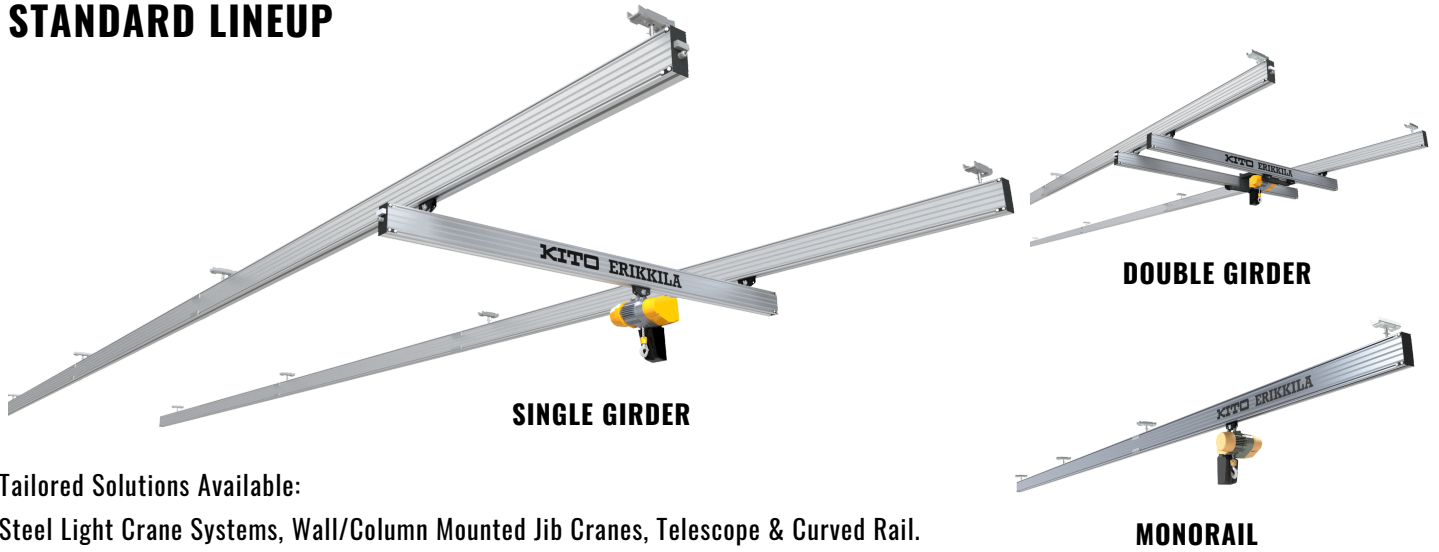

Tailored Solutions Available:
Steel Light Crane Systems, Wall/Column Mounted Jib Cranes, Telescope & Curved Rail.

ALUMINIUM PROFILES

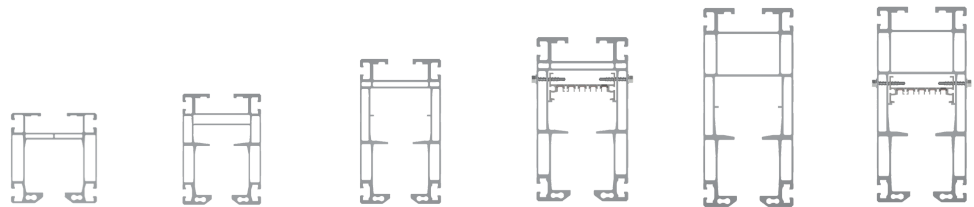

Profile	2/105	3/140	4/180	4/180R	5/220	5/220R
Profile Height (MM)	105	140	180	180	220	220
Profile Width (MM)	96	100	100	100	100	100
Weight (KG/M)	5.1	7.6	9.4	10.2	10.8	11.6
Internal Conductor Rail				✓		✓

ALUMINIUM PROFILE STANDARD ACCESSORIES

